



# AIR MOVEMENT SOLUTIONS

## AirFlow

*INSTALLATION MANUAL*





## BEFORE YOU BEGIN

# SAFETY & PRECAUTIONS

### Important Safety Information

To prevent SERIOUS INJURY, DEATH, and PROPERTY DAMAGE, you should read, understand, and follow the warnings and instructions in this manual before installing or operating the fan.

 **READ AND SAVE THESE INSTRUCTIONS.** This manual must always be kept with the fan and should remain with the fan if it is transferred or sold. Always give manual to fan owner following installation.



## WARNING



### FIRE, ELECTRIC SHOCK AND CRUSH HAZARDS.

#### TO PREVENT SERIOUS INJURY OR DEATH:

- **ALWAYS** mount fan directly from building structure that can withstand double the maximum hanging fan weight and install the Retention Cable.
- **BEFORE** installing or servicing your fan, **ALWAYS** disconnect the power by turning off the circuit breaker or breakers to the fan locations. If you cannot lock the circuit breakers in the off position, securely fasten a prominent warning device, such as a tag, to the electrical panel.
- All wiring must be in accordance with national and local electrical codes, including ANSI/NFPA 70. If you are unfamiliar with wiring or are in doubt, consult a qualified electrician.
- **DO NOT** install fan to be used in the presences of flammable vapors and gasses or in environments where combustible dust is present.
- **DO NOT** bend the blades or blade holders when installing or cleaning the fan.
- **DO NOT** insert foreign objects in between rotating fan blades.

#### Installation, adjustment, repair, or maintenance must be performed by qualified personnel.

Follow all safety practices and instructions during the installation, operation, and servicing of the fan. Failure to apply these safety practices could result in death or serious injury. If you do not understand the instructions, please call 1 (888) 319-1626 for guidance.

**Always check federal, state, and local codes before installing fan.**

Code compliance is the responsibility of the installer. Check all relevant codes to make sure that all product certifications, product listings, and building regulations are met.

Professional installation practice requires following local utility company guidelines for connecting to AC mains. This unit is for professional use only and is not required to comply with EN 61000-3-2:2006. This fan conforms to ANSI/UL standard 507, Electric Fans and is certified to CSA STD C22.2 No. 113, Fans & Ventilators.





**BEFORE YOU BEGIN**

## SAFETY & PRECAUTIONS



**WARNING**



**ELECTRIC SHOCK HAZARD**

### TO PREVENT SERIOUS INJURY OR DEATH:

- **BEFORE** installing or servicing your fan, **ALWAYS** disconnect the power by turning off the circuit breaker or breakers, to the fan locations and confirm Lockout/Tagout procedures are in place. If you cannot lock the circuit breakers in the off position, securely fasten a prominent warning device, such as a tag, to the electrical panel.
- All wiring must be in accordance with national and local electrical codes, including ANSI/NFPA 70. If you are unfamiliar with wiring or in doubt, consult a qualified electrician.
- Do not use an extension cord with fan.
- Do not remove covers while power is on.
- Do not use improper voltage source.

All fan controls and incoming power should be installed only by qualified technicians familiar with the requirements of the National Electrical Code and local codes. Failure to follow these guidelines will void the manufacturer's warranty.

All electrical controls are configured at the factory and are ready to use. No user adjustments are available. Follow the included installation instructions when installing this device to ensure proper operation. Do not make any changes to any part of the fan without first consulting Air Movement Solutions. Installation is to be in accordance with ANSI/NFPA 70: National Electrical Code and local codes.

The user is responsible for compliance with all international and National Electrical Code requirements with respect to grounding of all equipment. Many of the parts of this unit operate at line voltage.

Before installing, servicing, or cleaning the unit, switch power off at the service panel, lock the service disconnecting means, and confirm Lockout/Tagout procedures are in place to prevent power from being switched on accidentally. When the service disconnect means cannot be locked, securely fasten a prominent warning sign, such as a tag, to the service panel.

To reduce the risk of electric shock, serious injury, and death, only use this unit as intended by the manufacturer. If you have any questions, call 1 (888) 319-1626.





**BEFORE YOU BEGIN**

# SAFETY & PRECAUTIONS



**WARNING**



**CRUSH HAZARD**

To prevent serious injury or death, **ALWAYS** attach the Retention Cable to the fan motor and secure to the building structure on **EVERY** fan.

The Retention Cable, if installed per Air Movement Solutions specifications, can limit the distance the fan could fall in the unlikely event of mounting system failure. Failure to install and to secure the retention cable will void your warranty.

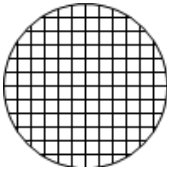

### Mark the Floor to Alert Personnel

When mounting a fan in an area where materials could be elevated and contact the rotating fan blades, mark or paint the floor with a large crosshatched circle, similar to the figure to the left, to alert personnel of the overhead fan locations.

### Weight and Torque Considerations

Always mount fan directly to building structure that can withstand approximately double (2x) the maximum hanging weight of the fan.

The maximum hanging weight of a 24' fan with a 4' downrod is 150 lbs and a maximum torque of 75 ft lbs.

If there is any uncertainty about the potential for the building structure to withstand double the maximum hanging weight of the fan, a professional structural engineer should perform a thorough evaluation of the building prior to purchasing the fans. Air Movement Solutions provides guidelines for mounting fans; however, it is the sole responsibility of the building owner and installer to ensure the safety of the mounting system and retention cable, the building structure is sound, and the installation complies with all federal, state, and local codes.

### Always use Personal Protective Equipment

You should always wear Personal Protective Equipment, such as a Hard Hat, Safety Glasses, and a Fall Harness when installing industrial fans.

### Damaged Equipment

Never operate or install any fans or fan accessories that appear to be damaged. Failure to follow this instruction can result in death, serious injury or equipment damage.

To reduce the risk of personal injury, do not bend the blades or blade holders when installing or cleaning the fan.

Do not insert foreign objects in between rotating fan blades.

### Service

If the fan does not operate properly using the procedures in this manual, remove all power to the unit and contact 1 (888) 319-1626 for further assistance.



## BEFORE YOU BEGIN

# FAN PLACEMENT

### **ALWAYS MOUNT FAN SO THE BOTTOM EDGE OF BLADE TO THE FLOOR IS AT LEAST 10 FEET FROM THE FLOOR AND AT LEAST 25% OF FAN DIAMETER FROM THE CEILING.**

A large fan, 20 to 24 foot in diameter, performs best at 20 to 30 feet above the floor, but acceptable performance has been demonstrated as low as 10 feet and as high as 50 ft.

#### **Always mount fans away from the following:**

##### **Sprinkler Systems**

Prior to installing fans, review all codes applicable to sprinkler systems and fans to ensure code compliance and refer to NFPA 13: Fire Sprinkler System Installation. In any installation where fire sprinklers are present, the fan should not interfere with their operation.

- Fans should be located at least 3 feet below a sprinkler deflector.
- Fans should be centered between 4 adjacent sprinklers.
- The Industrial Control Panel should be connected to a fire relay system, which can stop the fans in the event a fire occurs.

It is your responsibility that the installation complies with the applicable codes. For assistance, please call 1 (888) 319-1626.

##### **Walkways and Mezzanines**

If the building has elevated walkways or mezzanines, mount the fans so that a person cannot reach the rotating blades in any way. Position fans so that the tips of the blades are at least 5 feet away from any area where a person may be able to extend outward to reach them.

##### **Lights and Skylights**

If possible, avoid mounting fans directly below lights or skylights to avoid any strobe effect caused by moving blades.

There should be a minimum of 2 feet between the blades and any light fixture.

##### **Air Discharge Locations**

Fans should not be located directly beneath any vertical air discharge. This includes air conditioning units and evaporative coolers. Such equipment can be used effectively in conjunction with high-volume, low-speed (HVLS) fans; however the discharge of the unit must be located outside the swept area and at a distance of at least two times the diameter of the fan. For horizontal air discharge, the fan cannot be placed in direct path at any distance.

##### **Windy Locations**

Do not operate or install fans in outdoors or in areas exposed to wind. Failure to follow this instruction can result in death, serious injury, or equipment damage.

##### **Wet Locations**

DO NOT locate fans where they may come into direct contact with water. These fans are only suitable for mounting in damp locations.

##### **Other HVLS Fans**

See the chart on the next page to determine proper spacing between adjacent fans.



## BEFORE YOU BEGIN

# FAN PLACEMENT

## FAN PLACEMENT

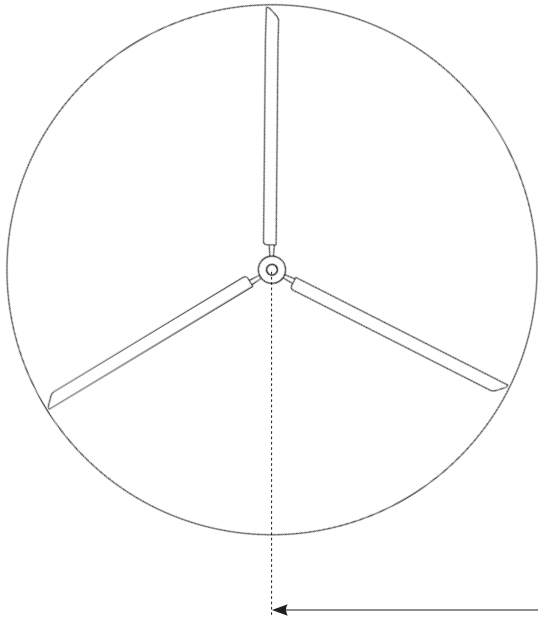

FAN SPACING CHART	
AMS AIRFLOW	
A	B
DIA	MIN-MAX
24 ft	60ft - 96ft
20 ft	50ft - 80ft

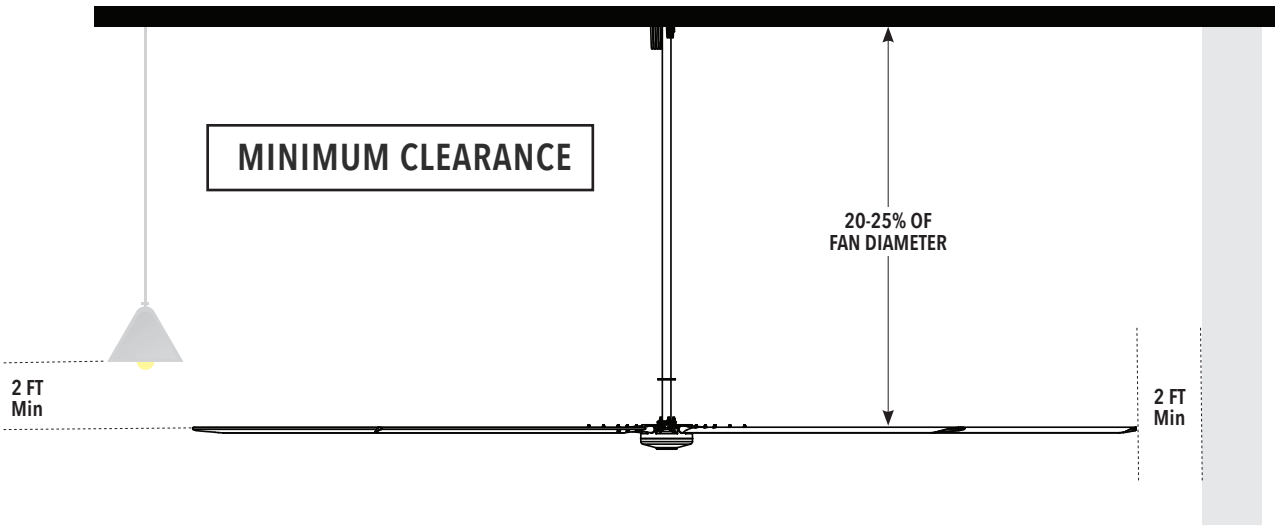
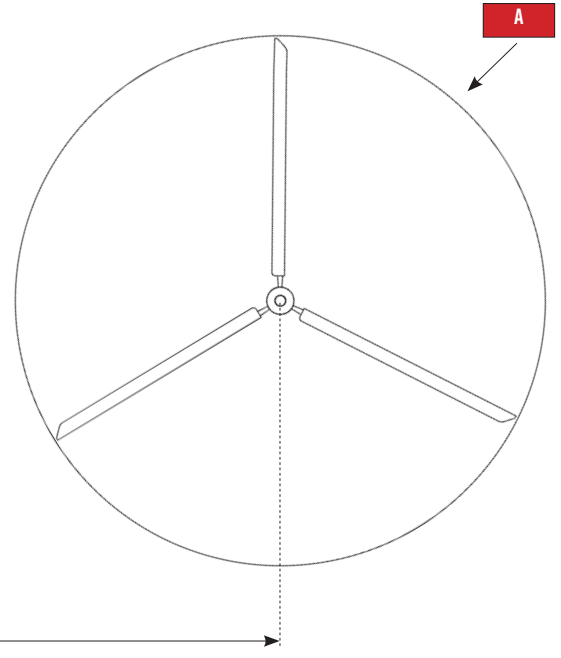

**BEFORE YOU BEGIN****TOOLS NEEDED**

<input type="checkbox"/>	Metric Combination Wrench Set (10mm - 19mm)
<input type="checkbox"/>	Metric (Deep & Short) Socket and Ratchet Set
<input type="checkbox"/>	Standard (Deep & Short) Socket and Ratchet Set
<input type="checkbox"/>	Metric Allen Wrench Set
<input type="checkbox"/>	Metric Allen Socket Set
<input type="checkbox"/>	Tape Measure
<input type="checkbox"/>	Magnetic Level (Magnetic post level recommended)
<input type="checkbox"/>	Torque Wrench
<input type="checkbox"/>	Wire Rope Cutters (optional)
<input type="checkbox"/>	Phillips and Flat Head Screwdrivers
<input type="checkbox"/>	#10 to #14 AWG Strippers (optional)
<input type="checkbox"/>	Multimeter (optional)
<input type="checkbox"/>	Cat5 Termination Tools (optional)
<input type="checkbox"/>	Cat5 Tester (recommended)
<input type="checkbox"/>	15mm Socket
<input type="checkbox"/>	6mm Hex Key (Allen) Wrench





# BEFORE YOU BEGIN

# IN THE BOX

## FAN COMPONENTS

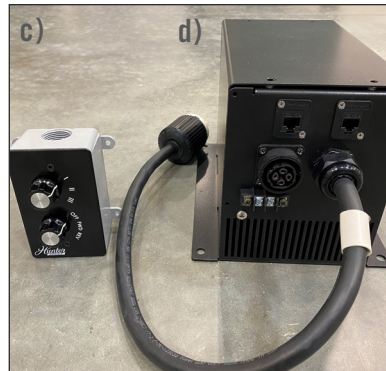
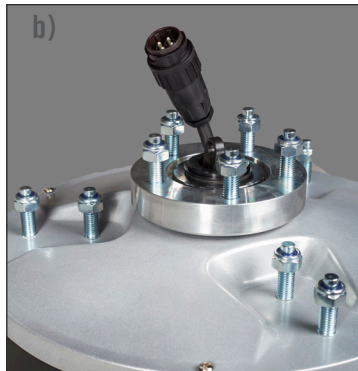

### FAN COMPONENTS

- a) (1) Downrod
- b) (1) Motor & Motor Nuts
- c) (1) HMI Controller(s)
- d) (1) VFD Control Panel
- e) Blades: 3

### MOUNTING HARDWARE KIT (EXCLUDING XP/RM)

- a) (2) Shims
- b) (2) Clamps
- c) (4) Bolts, Nuts, and Washers

### GUY WIRE KIT (EXCLUDING XP/RM)

- a) (2) Gripper Kit
- b) (4) Beam Clamps
- c) (4) Turnbuckles

## MOUNTING HARDWARE KIT

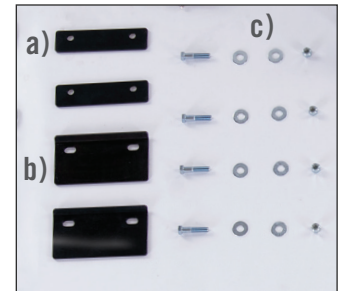

## GUY WIRE KIT

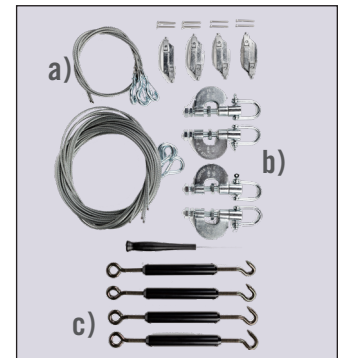

## COMMUNICATON KIT



### COMMUNICATION KIT

- a) 100ft Cat5 Cable (Terminated)

### INSTALLATION MANUAL

- a) AMS Installation Manual



## BEFORE YOU BEGIN

# PRE-INSTALLATION CHECKLIST

- |                          |   |
|--------------------------|---|
| <input type="checkbox"/> | A structural engineer has approved the mounting structure.  |
| <input type="checkbox"/> | The location of the fan will allow for a minimum of two feet of blade clearance from any obstruction and at least 10 feet of clearance above the floor.                         |
| <input type="checkbox"/> | The fan location will not be subjected to high winds.   |
| <input type="checkbox"/> | If installing multiple fans, reference the fan placement chart on page 7 for optimal spacing.   |
| <input type="checkbox"/> | The control panel, motor and blade assemblies are all marked with the diameter. Ensure the markings all match when assembling the fan.  |
| <input type="checkbox"/> | The control panel voltage markings should match your buildings supply power.  |
| <input type="checkbox"/> | <b>The fan power should be installed within 3 ft of the top of the downrod.</b><br><i>Please refer to the chart on page 22 for the appropriate receptacle and breaker size.</i> |
| <input type="checkbox"/> | Inspect product to ensure there are no visible damages or defects to fan(s) components ( <i>Refer to page 9 for fan components list</i> ).                                      |
| <input type="checkbox"/> | Ensure fan components have not been disassembled or modified beyond the scope which AMS Fans offers in their product line.  |



## BEFORE YOU BEGIN

# ADJUSTABLE DOWNROD

THERE ARE THREE DIFFERENT ADJUSTABLE DOWNROD LENGTH CONFIGURATIONS:

2.5 - 4 FT (0.77 - 1.22m) | 4.5 - 6 FT (1.38 - 1.83m) | 6.5 - 10 FT (1.99 - 3.05m)

DOWNROD WILL SHIP PRE-WIRED AND FULLY ASSEMBLED IN THE SHORTEST CONFIGURATION.



### TOOLS NEEDED

- 15mm socket
- 6mm hex key (Allen) wrench

*Downrod length adjustments may be made in increments of 6".*



## BEFORE YOU BEGIN

# ADJUSTABLE DOWNROD

## Adjusting Downrod Length

There are three different adjustable downrod length configurations: 2.5 - 4 FT (0.77 - 1.22m) | 4.5 - 6 FT (1.38 - 1.83m) | 6.5 - 10 FT (1.99 - 3.05m). Each configuration will be shipped from the factory in the shortest configuration but will have all necessary components for the longest configuration. If a longer length of downrod is necessary for the install, adjust the downrod at ground level before installing to the building structure.

### How to Adjust the Downrod Length:

# A

Remove the two adjustment bolts and hardware.

# B

Slide the upper and lower tubes apart until the matching pair of adjustment holes line up to achieve desired length.

# C

Replace the two adjustment bolts and hardware.

# D

Torque the adjustment bolts, clockwise, to 53.8 ft-lbs., until bolts are tightly secured.

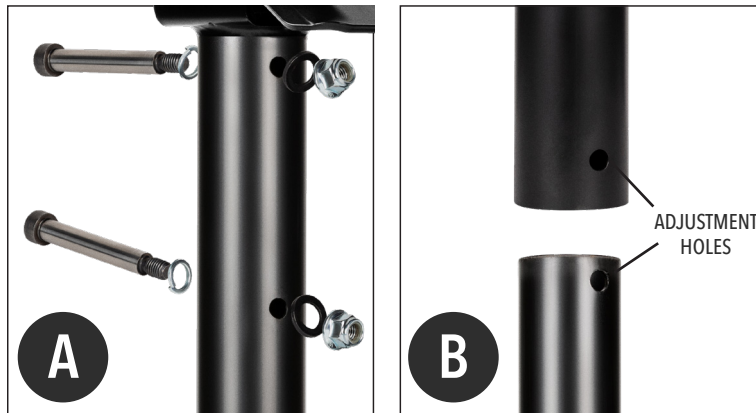

## NOTE

Ensure that bolt is tightly secured to the downrod and that the washer did not get hung up on the end of the adjustment bolt, causing the bolt to be loose.

**Do not** install downrod with only one bolt or extend downrod beyond where both bolt holes of the inner and outer tubes line up. **Do not** extend past warning sticker.

**Do not adjust downrod length while downrod is mounted or when the fan is attached to the downrod. Length adjustment should happen at the ground level.**

Beware pinching the motor cable or safety cable while replacing adjustment bolts.

**Mounting Adjustable Downrod:** Follow mounting instructions starting on page 13.



# INSTALLATION

# STEP 1: MOUNTING

## ! WARNING



**CRUSH HAZARD.** To prevent **SERIOUS INJURY** or **DEATH**, **ALWAYS** mount fan directly from building structure that can withstand double the installed fan weight.

**A**

Secure bracket and downrod to lift and raise to an I-Beam that is part of the building structure.

**B**

Assemble shims and clamps on one side of the bracket per the figure below.

Hook the clamp on one side of the I-beam and tighten hardware until the clamp and shim are snug but can still be moved.

**C**

Assemble the opposing shim and clamp on to the I-beam and Tighten using a 3/4" socket and wrench.

**D**

Center the mount under the I-beam. Check that clamps have maximum engagement on both sides and tighten hardware.

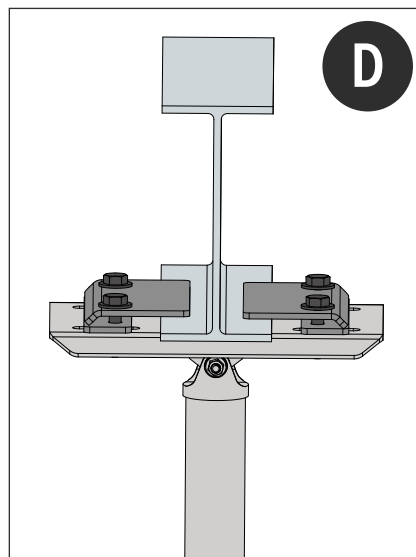
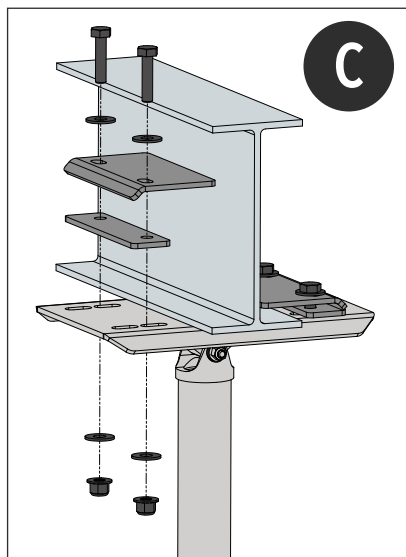
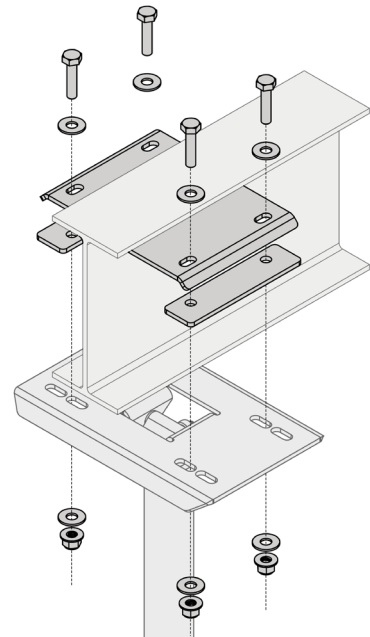
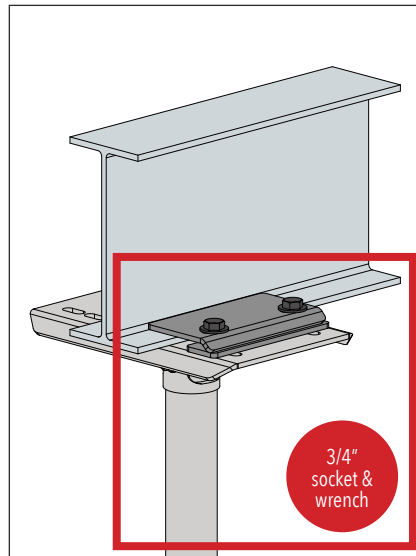
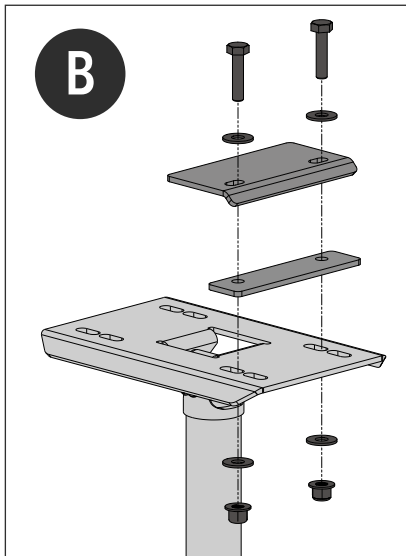

**WARNING: SUPPORT DIRECTLY FROM BUILDING STRUCTURE**



## INSTALLATION

# MOUNTING CONFIGURATION

CHANNEL HEIGHT	MATERIAL THICKNESS	MAXIMUM SPAN LENGTH
1 5/8"	12 GA	84'
1 5/8"	14 GA	72'
1 5/8"	16 GA	60'
1 3/8"	12 GA	60'
7/8"	12 GA	30'
3 1/4"	12 GA	240"
2 7/16"	12 GA	156"

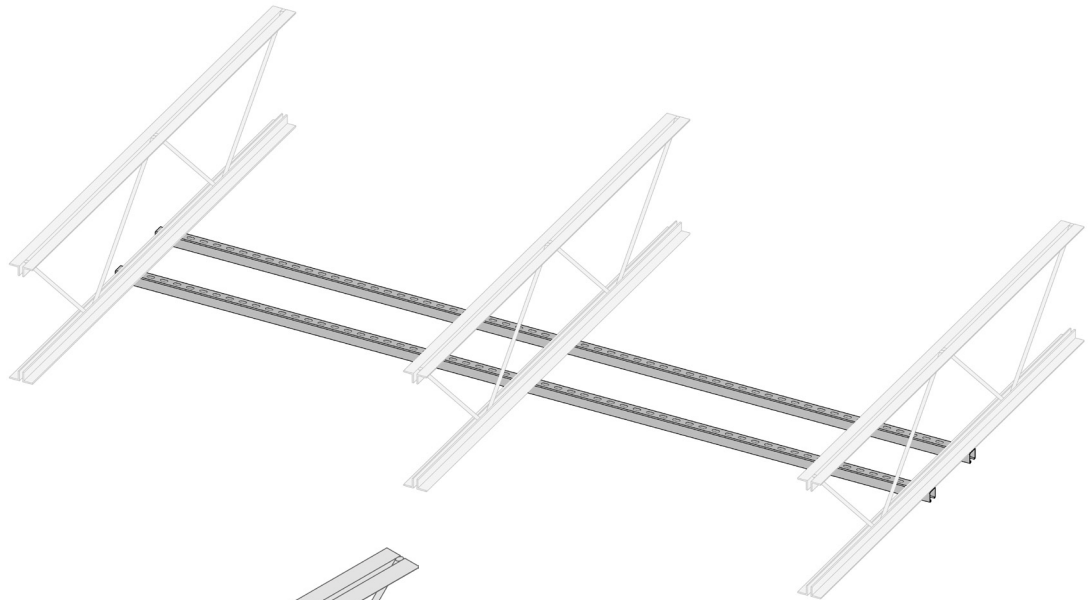

### K-BAR MOUNTING

Example of mounting to a truss with standard mount hardware.

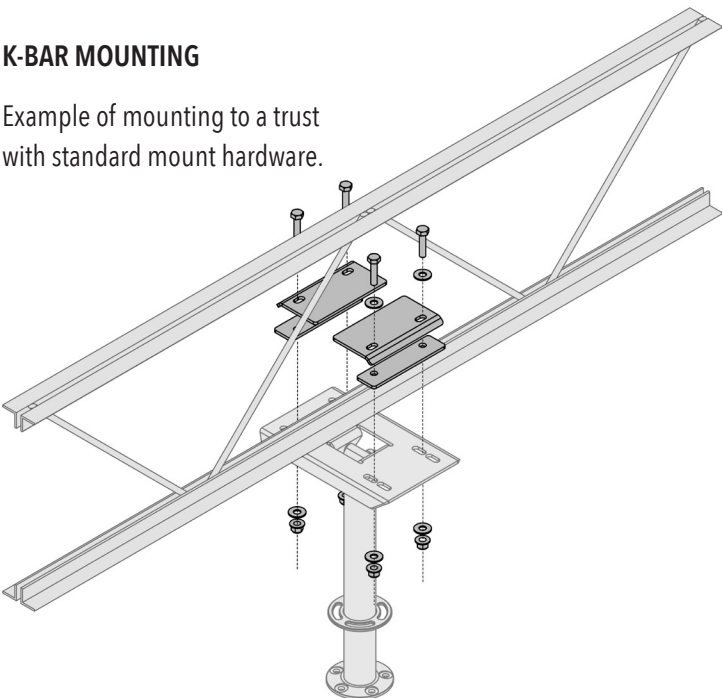

### STRUT CHANNEL MOUNTING

If bracing is required unistrut can be used, we recommend spanning at least three trusses or perlins.

## REMINDER

*The retention cable should always be secured around the building structure or a beam, not around something bolted on, such as a strut channel.*



## INSTALLATION

# STEP 1: MOUNTING

**A**

Select proper strut channel from the chart.

**B**

Use strut channel or similar to span three points of the building structure and create a stable attachment point for the fan.

**C**

Bolt fan mounting plate to attachment point using 1/2" grade 5 bolts and nylon locking nuts.

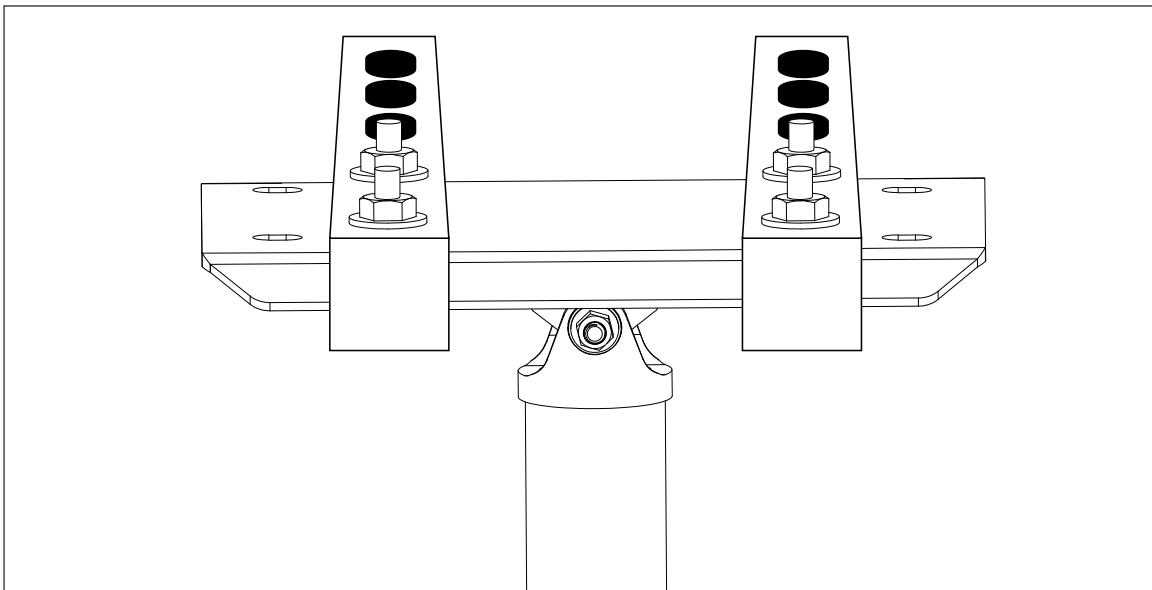
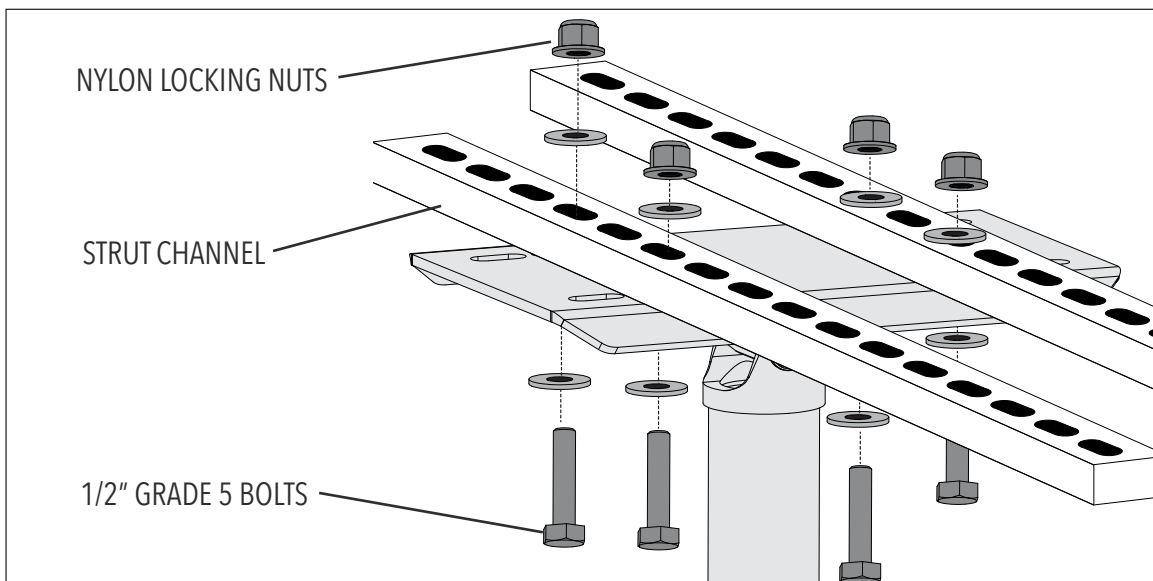

**WARNING: SUPPORT DIRECTLY FROM BUILDING STRUCTURE**



## INSTALLATION

# STEP 2: RETENTION SYSTEM

### ⚠️ WARNING



**CRUSH HAZARD.** To prevent **SERIOUS INJURY** or **DEATH**, **ALWAYS** mount fan directly from building structure that can withstand double the installed fan weight.

### A

Wrap retention cable around building structure that can withstand double the installed fan weight.

### B

Secure remaining cable to itself with cable clamps.

### NOTE

*Leave approximately 3" of slack in the wire and the cable at the top of the downrod opening.*

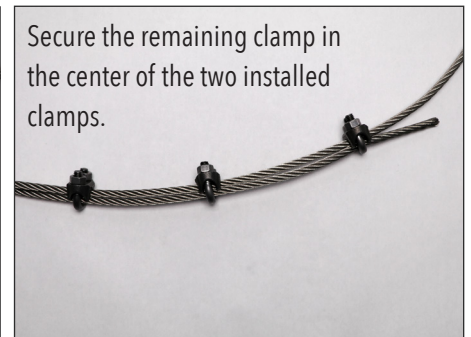
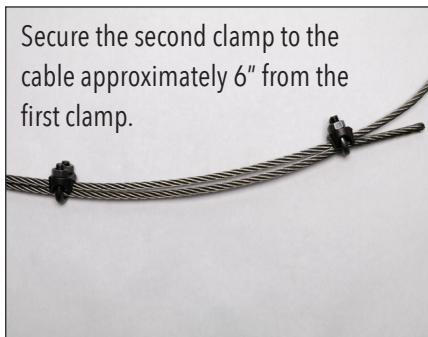
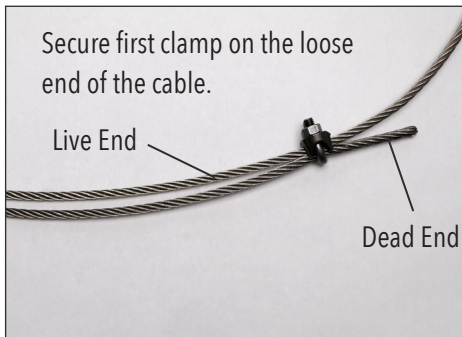
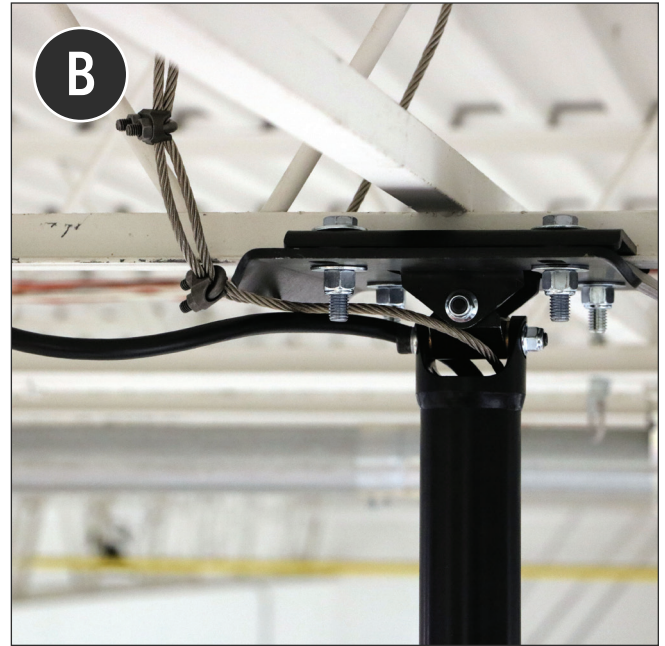
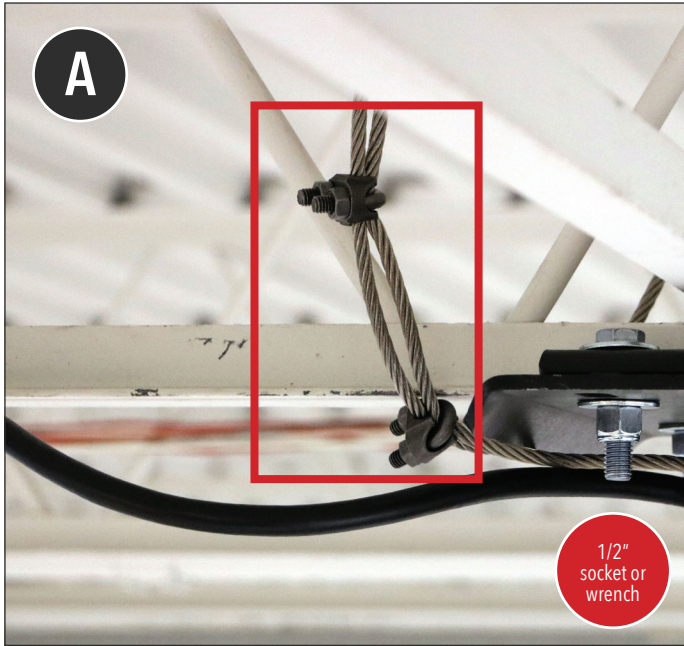

Orient the u-bolt on the "dead" end of the Retention Cable and the clamp on the "live" portion of the retention cable. If done incorrectly, the U-bolt could crush the wire when tightened and can reduce the strength of the wire.





# INSTALLATION

## STEP 3: MOTOR ASSEMBLY

### ! WARNING



**CRUSH HAZARD.** To prevent serious injury or death, **ALWAYS** attach the retention cable to the fan motor and secure to the building structure on **EVERY** fan.

### A

Insert retention link into fork and align holes.

Insert clevis pin into retention rod and secure with provided clip.

### B

Align the connector from the motor with the downrod connector.

Twist the collar on the connector to complete the connection. Do not force. Connectors should slide together as they twist.

Be sure to twist until the connection locks.

Zip tie the motor cable to the safety cable to reduce the opportunity to pinch the cable

### C

Lift motor up to downrod while pushing cables into downrod.

Feed the press studs through downrod flange.

Secure with nylon lock nuts. (Pull excess wire and cable through top of downrod.)

### NOTE

Leave approximately 3" of slack in the wire and the cable at the top of the downrod opening.

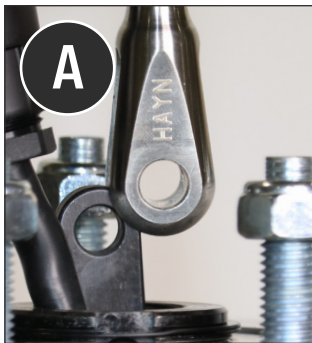

### NOTE

Be sure not to pinch the motor cable when raising the downrod into place. A zip tie is recommended to secure the motor cable to the safety cable to ensure that pinching does not occur.

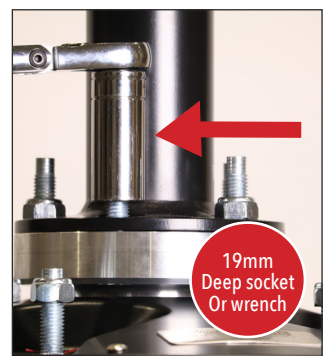
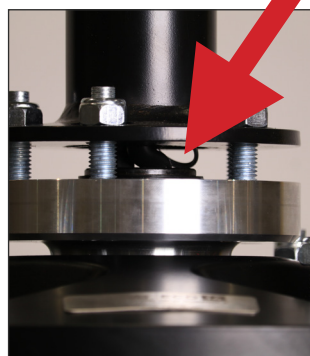
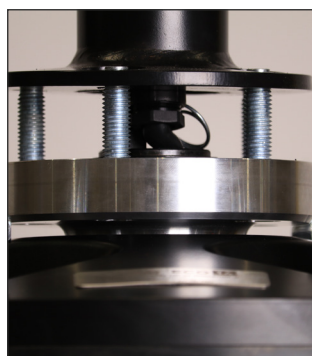
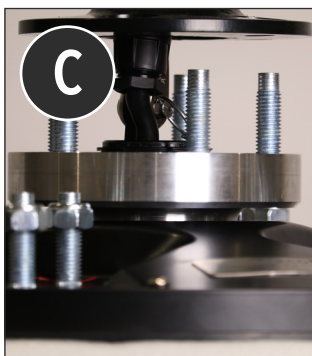



## INSTALLATION

# STEP 4: VARIABLE FREQUENCY DRIVE (VFD) CONTROL PANEL

### A

The VFD control panel should be mounted directly above the fan and downrod.

### B

Position the VFD control panel with plug connectors facing down.

If using uni-strut attached to the building structure, secure industrial control panel with four 1/4"-20 fasteners, one in each corner of the panel.

### C

Connect the VFD cable from fan to the industrial control panel. Orient the cable to the connection so it engages slightly. Twist to lock in place. Secure excess cable to mounting location.

### D

Connect the communication cable (Cat 5) to one of the COMM terminals and run cable down to the control location.

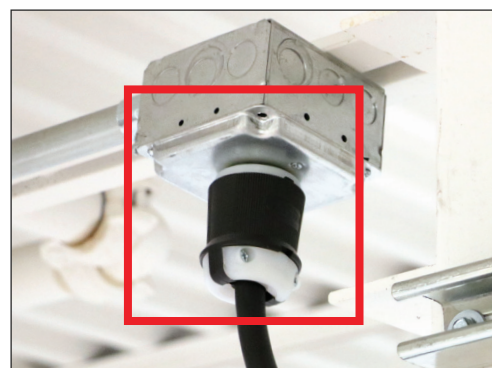

## NOTE

*Twist Lock will act as a disconnect.*

**CAUTION: DO NOT ENERGIZE CIRCUIT UNTIL MECHANICAL INSTALLATION IS COMPLETE**

## NOTE

*Align male connector with female receptacle. Do not force connector into receptacle.*

## NOTE

*USE COMM 2 FOR MULTIFAN INSTALL*



## INSTALLATION

# STEP 5: GUY WIRES

### ⚠️ WARNING



- Attach guy wire to building structure while maintaining a 45° angle between the ceiling and the guy wire.
- Do not wrap guy wires around the building structure. The guys wires could fray if in contact with the building structure.

### A

Attach beam clamps to structure. Clip 15' guy wire end to beam clamp.

### B

Make sure that guy wires are evenly spaced 90 degrees apart. Do not place guy wires on the same plane as the downrod, or another guy wire.

### C

Feed one end of the 15' guy wire through the Gripple.

### D

Clip end of the 2' guy wire to the eyebolt of the turnbuckle.

### E

Feed the opposite end of the 2' guy wire through the Gripple as the 15' guy wire from step B.

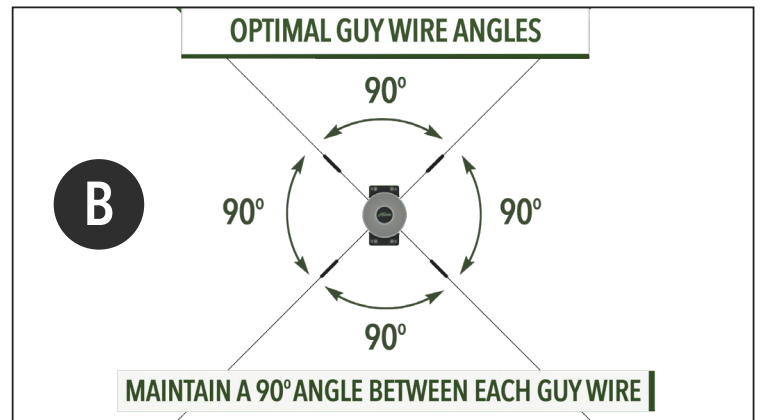
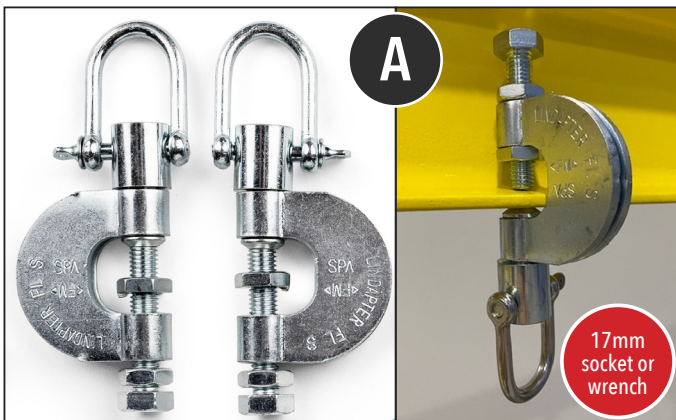

## NOTE

Make sure the guy wires do not interfere with cables or other obstructions.

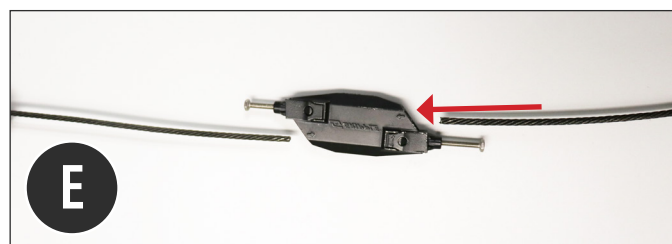
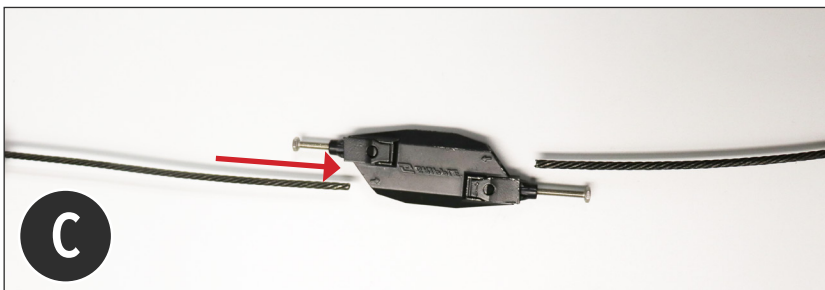



## INSTALLATION

# STEP 5: GUY WIRES

## ⚠️ WARNING



- Attach guy wire to building structure while maintaining a 45° angle between the ceiling and the guy wire.
- Do not wrap guy wires around the building structure. The guys wires could fray if in contact with the building structure.

## F

Feed guy wires through disc to hold in place during turnbuckle installation. Pull excess cable until guy wire is taut. Place level against the downrod and tighten the turnbuckles by hand in a crisscross pattern, periodically checking to ensure the downrod is plumb and the fan is level.

## G & H

Tighten bolts on Gripples, and then tighten the set screws on the turnbuckles.

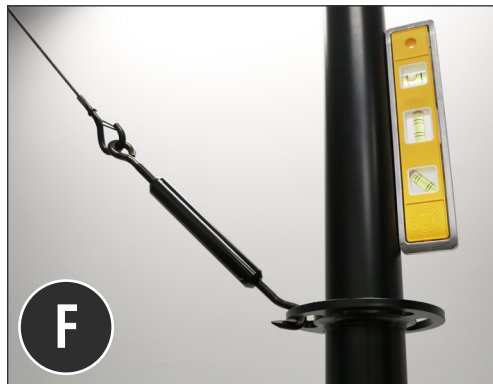



## INSTALLATION

# STEP 6: BLADES

**A**

To install blade, insert the press studs through the holes in the blade holder.

Remember to install with the numbers facing up.

**B**

Start the nylon lock nuts onto the press studs to hold in place.

**C**

Tighten the nylon locknuts on the press studs using the 19mm wrench or socket.

**D**

Repeat steps A-C for each of the two remaining blades.

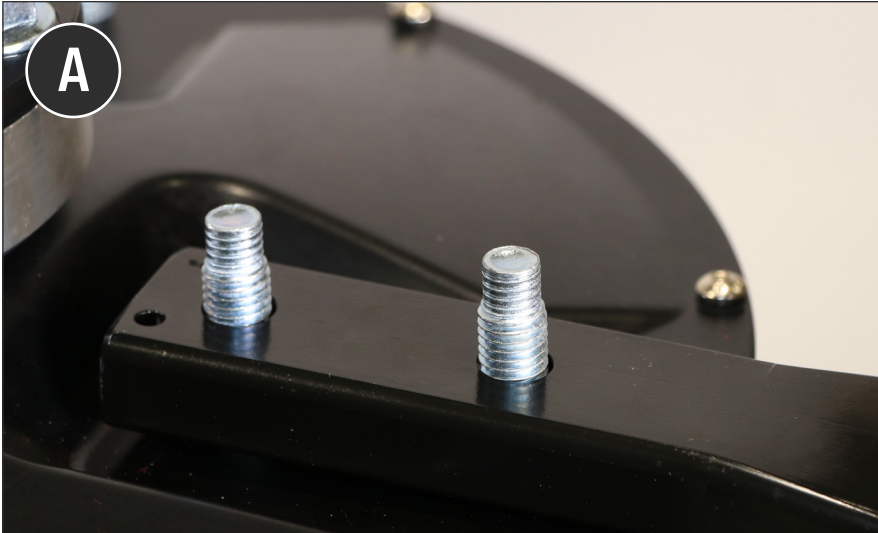



### Electrical Plug Requirements

Voltage	Phase	Plug (included)	Receptacle
200-240V	Single	HBL2321	L6-20R
200-240V	Three	HBL2421	L15-20R
380-480V	Three	HBL2431	L16-20R

HBL2321



HBL2421



HBL2431



Do not use extension cord with fan.  
 Do not remove covers while power is on.  
 Do not use improper voltage source.

## AIRFLOW MAX AMP DRAW

FAN DIAMETER	220V / 1PH	RECOMMENDED BREAKER SIZE	220V / 3 PH	RECOMMENDED BREAKER SIZE	480V / 3PH	RECOMMENDED BREAKER SIZE
24 ft	6.3A	10A	2.6A	5A	2.3A	5A
20 ft	5.5A	10A	2.9A	5A	2.1A	5A



## AIRFLOW 3 SPEED ANALOG CONTROLLER MOUNTING

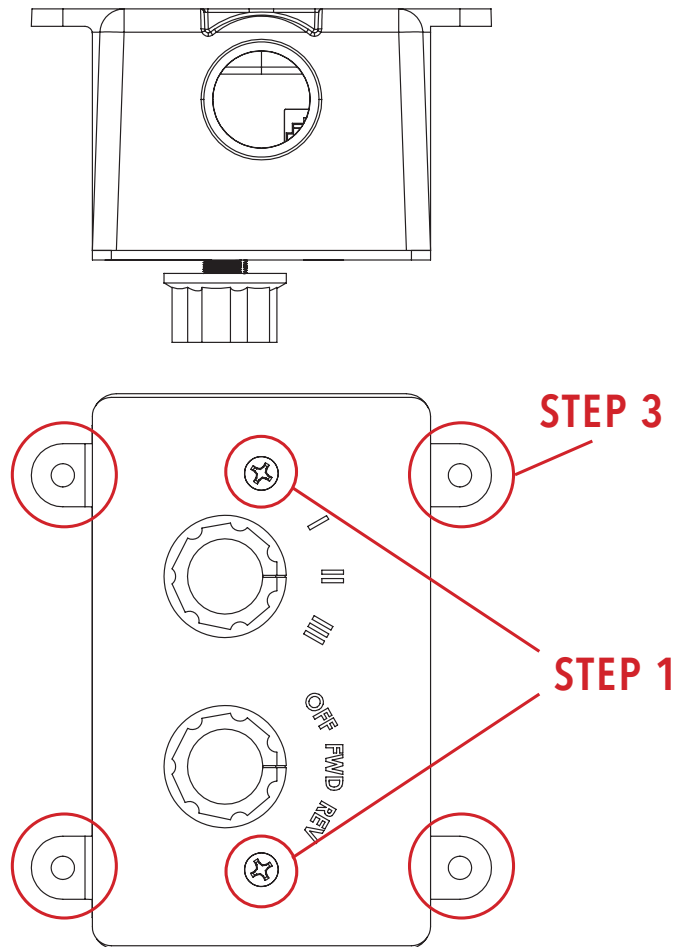

1. Using a phillips head screwdriver remove the 2 screws on the controller faceplate.
2. Feed one end of the CAT5e cable through the desired junction box opening and insert it into the connector jack on the inside of the controller. Then replace the faceplate and re-install the 2 screws.
3. Using the mounting bracket as a guide mark the 4 locations the mounting hardware will anchor to the wall or surface.
4. Using appropriate anchoring hardware for the surface type, anchor the the mounting bracket and controller to the surface in the 4 locations.
5. The other end of the CAT5e cable will be ran to the VFD into the Comm 1 port.



When daisy chaining fans with one control, the layout will be similar to the one below:

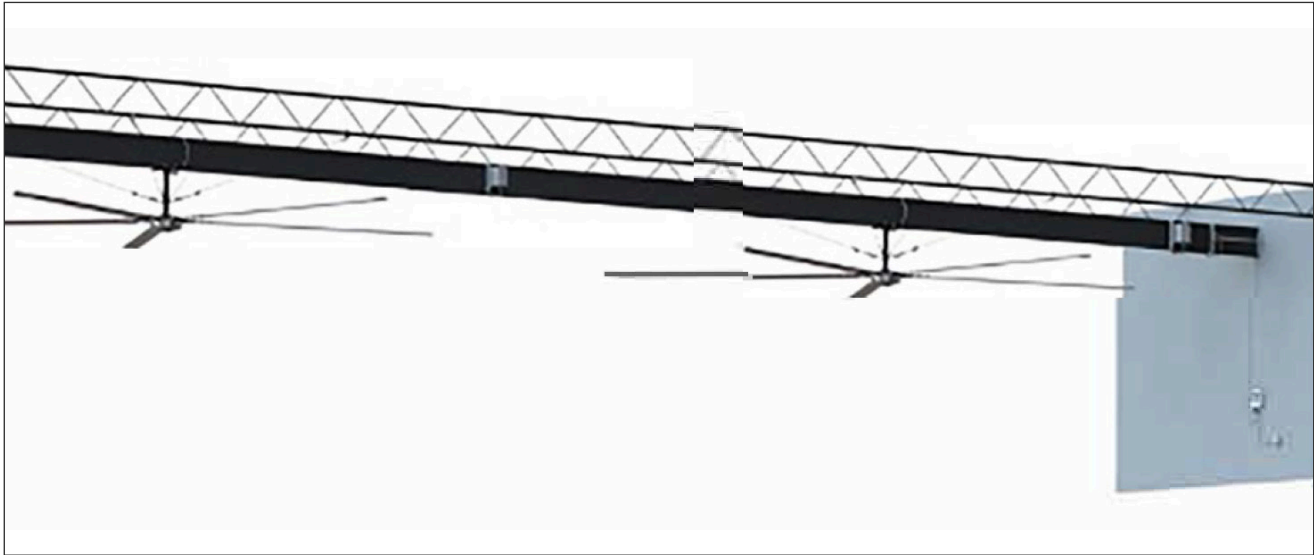

## A

You will have one Cat5e cable from the HMI to the Drive of the first fan:

## B

When you first apply power to the HMI, it will ask how many fans on the circuit. All other critical programming is done by AMS Fans.

## C

The input cable should plug into Comm 1 on the first connected VFD Control Panel. When connecting to a second fan connect the cable to Comm 2 (as an output) and connect it to Comm 1 as an input to the subsequent fan. Repeat for more fans in series where Comm 1 is the input and Comm 2 is the output. Note that Comm 2 will not be connected on the final fan.

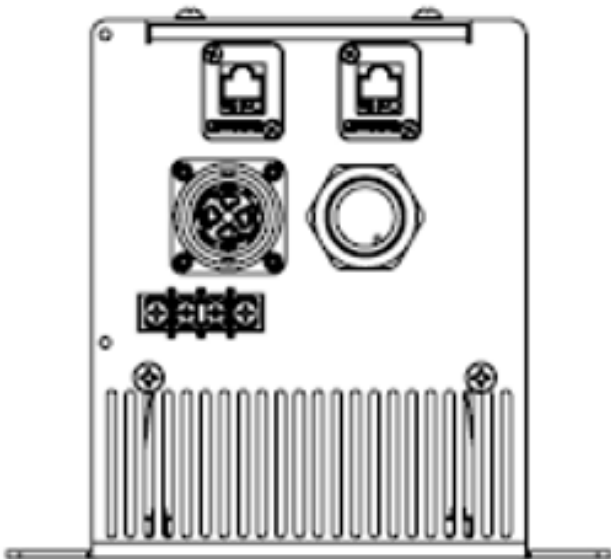

## NOTE

*Must use shielded Cat5e-6 cable for connections with a maximum distance of 300 ft of cable for daisy chaining*





## REFERENCE

# FIRE PANEL (FIELD WIRING)

Fire Relay arrangement for multiple fans (30 Fan Maximum)

### DRY CONTACTS: NORMALLY CLOSED

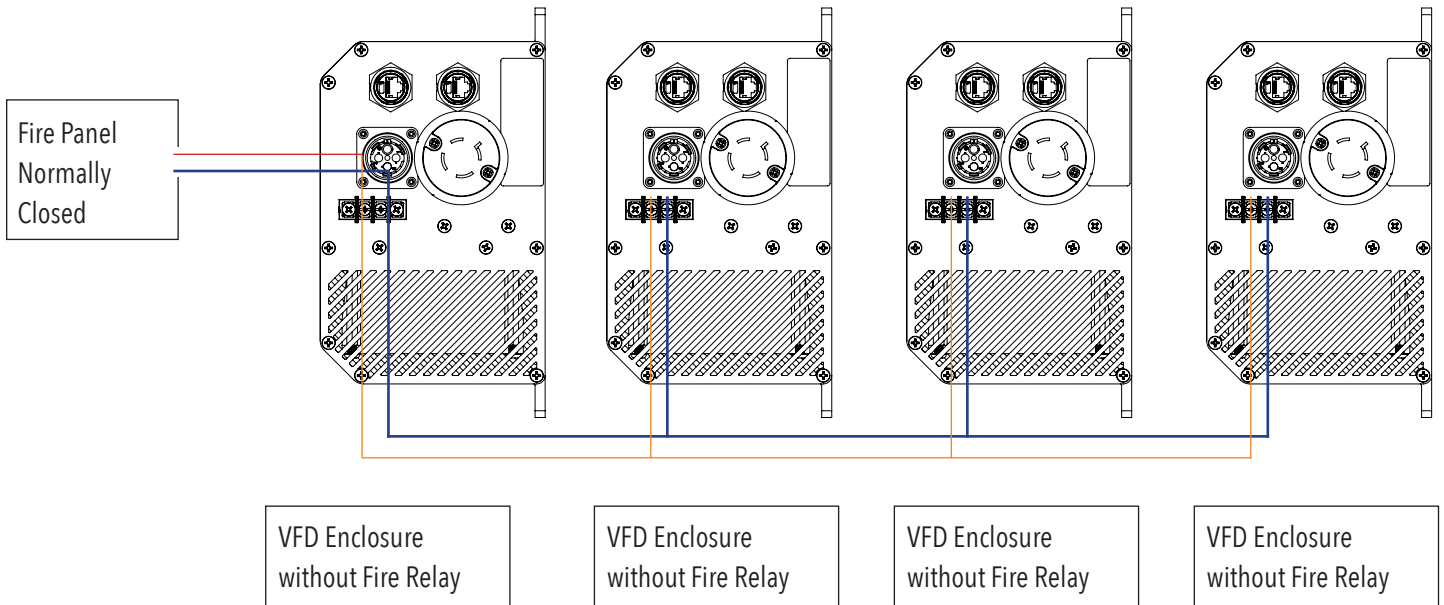

### NORMALLY ENERGIZED/UNENERGIZED

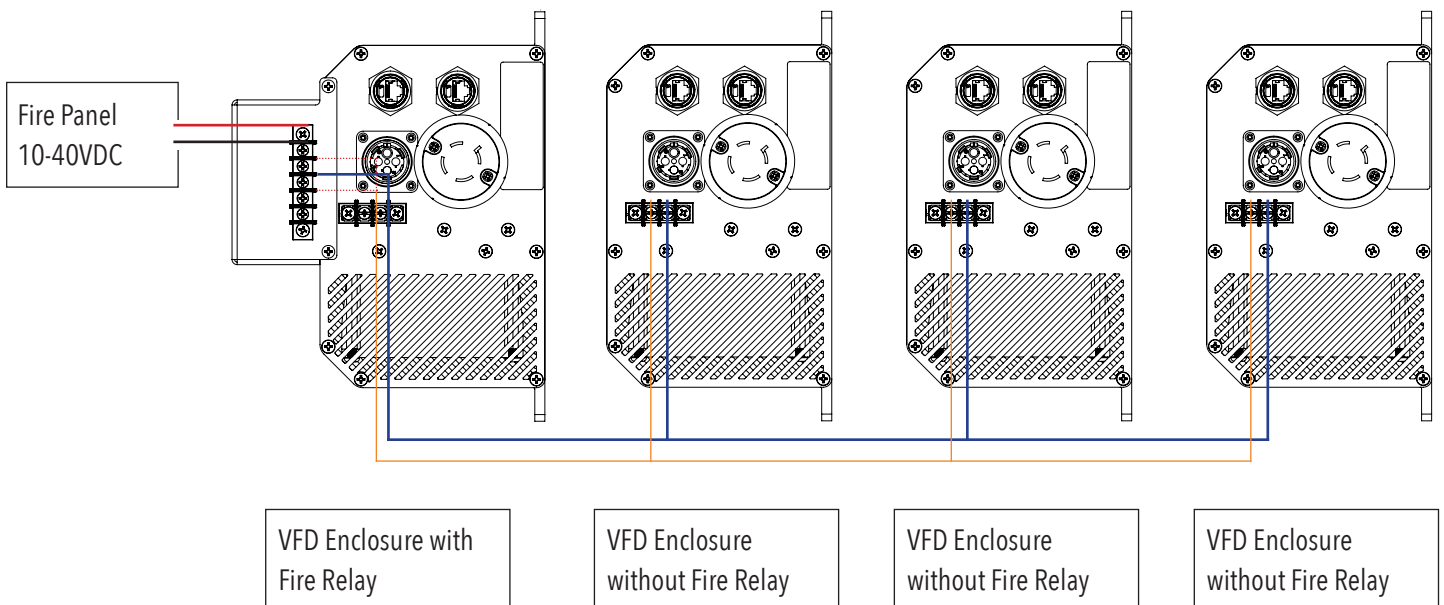

**WARNING****ELECTRIC SHOCK HAZARD****TO PREVENT SERIOUS INJURY OR DEATH:**

- **BEFORE performing maintenance or service, ALWAYS disconnect the power by turning off the circuit breaker or breakers to the fan locations and confirm Lockout/Tagout procedures are in place.**
- **If you cannot lock the circuit breakers in the off position, securely fasten a prominent warning device, such as a tag, to the electrical panel.**
- **Do not remove covers while power is on.**

**Blade Cleaning**

Depending on the commercial application, dust or other particulates can build up on the fan blades over time. At least every 12 months, a maintenance person or skilled trade professional, who has experience using a lift, should clean the blades using a rag or sponge and hot water or regular cleaning solutions. DO NOT use chlorine or any chemicals containing chlorine or the blades may be damaged.

**Retention System Check**

Each fan is installed with a retention system. Every 12 months, check that the retention cable is properly attached to the building structure. Inspect the visible portions of the retention cable for damage, including fraying.

The retention cable is an important part of the safety system and protects users in the unlikely event of a catastrophic situation. It is critical for fan owners to ensure that it is intact and properly secured.

**Replacement Parts**

Please call 1 (888) 319-1626 for replacement parts.

**Service**

If the fan does not operate properly using the procedures in this manual, follow Lockout/Tagout procedures for your facility and lockout all power to the unit and contact 1 (888) 319-1626 for further assistance.



## Symptom

## Possible Solution

---

### **FAN WILL NOT START**

- Verify that the fan's circuit breaker has power and that it is on.
  - Verify that the VFD's receptacle has power and that the VFD is plugged in.
  - Check for secured plug connections. Each connection should be checked to ensure they are fully engaged.
  - Inspect for loose wiring connections. Each termination should be checked to be sure they are firmly tightened.
- 

### **IF THE ABOVE IS VERIFIED AS WITHIN SPECIFICATION**

- Cycle the power to the VFD by flipping the circuit breaker off for a minimum of three minutes. Flip the circuit breaker back on and check the fan's operation.
- 

### **MOTOR IS PULLING EXCESSIVELY HIGH AMPS**

- Make sure the motor voltage is a match for the supply voltage.
  - Make sure that correctly sized fan blades have been installed.
- 

### **FAN IS "SWINGING" AS IT RUNS**

- Check for correct fan blade installation. Be sure that all blades are the same size and that all blades have been properly installed and tightened.
  - Ensure all guy wires are tensioned properly and that the downrod is plumb.
  - Check for improper incoming air discharge. Make sure that no discharge is blowing directly on the fan.
- 

### **A FAN BLADE APPEARS TO BE 'SAGGING'**

- Make sure that the 'sagging' blade has been properly tightened.
- 

For situations beyond the scope of this guide, please call 1 (888) 319-1626.



Join the movement...

[www.AMSfans.com](http://www.AMSfans.com) - 1(888)319-1626

81011756 - 20230811